

DUAL BATTERY DB1

Cautions and Limitations:

- The Dual Battery is an alternative power supply for the SE400 family of respirators. It must only be used with the Battery that is supplied with the SE400; i.e., the B1 or later models. When used in accordance with these instructions and the respirators instructions, the respirator continues to provide full protection.
- Ensure that both batteries to be placed onto the Dual Battery system are fully charged. If they are not fully charged the performance time will be compromised.
- Ensure that the Dual Battery system ALWAYS has both batteries attached.
- Do not remove and replace the battery while the fan unit is operating. This may compromise the protection the fan unit provides.
- Do not place the Dual Battery system onto the SE400 Battery Charger. It will not charge the batteries and doing so may affect the batteries or the charger.

To attach the Dual Battery system to the Backpack:

- Choose the location on the backpack that best suits the user. There are TWO possible locations for the dual battery holders. One is at the top of the padded shoulder strap; the other is at the bottom of the shoulder strap.

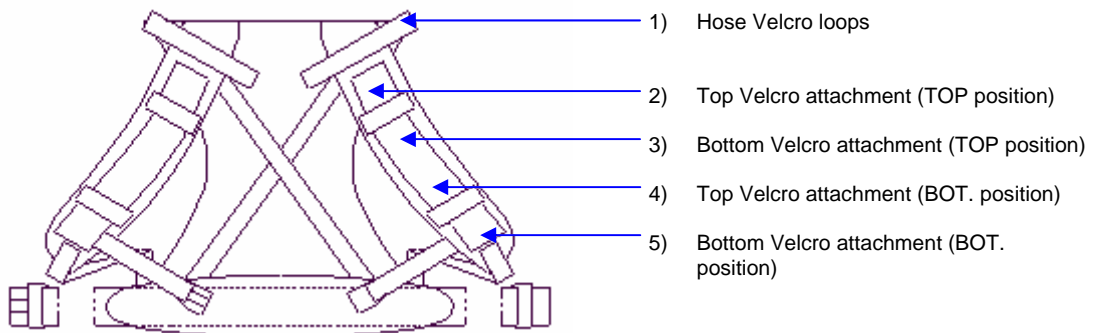

- The system is most comfortable if the cables from the holder are always facing upwards. With the holder in this orientation, thread the top Velcro attachment through the top eyelets of the dual battery holder. Once in place, thread the bottom Velcro attachment through the bottom eyelets of the dual battery holder.

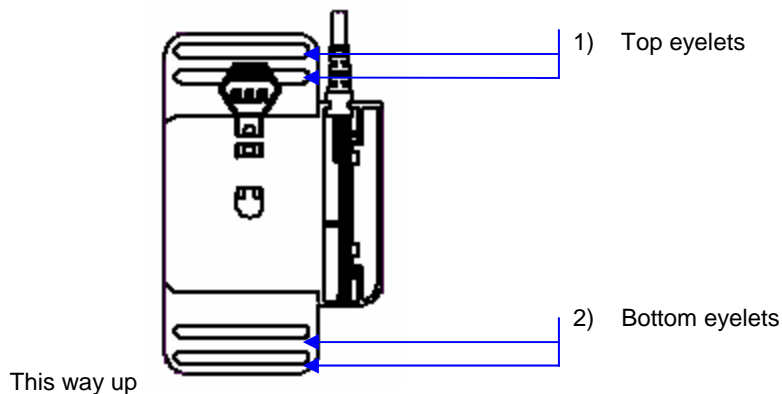

- Attach the main battery to the SE400 fan unit;
 - Make sure that the terminals on both the battery main and the battery bay of the fan unit are clean and intact
 - Withdraw the locking slide on the fan unit
 - Press down the black locking tongue
 - Hook the battery onto the fan unit and swing it around into place
 - Release pressure on the locking tongue
 - Push the locking slide back into place

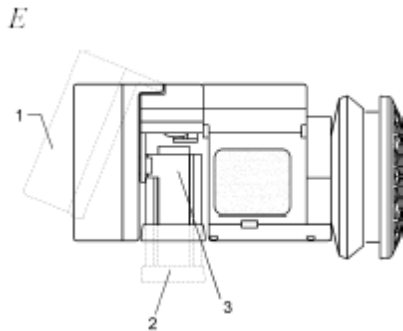

- 1) Battery Main
- 2) Locking slide
- 3) Locking tongue

- If the cables from the holder require retainment, they may be retained by the Velcro loops on the backpack where the hose for the SE400 passes through.

To fit battery:

- Remove the key from the key guide slot in the dual battery holder.
- Place the battery onto the holder and press it down firmly.
- While holding the battery in place by hand, push the key into the key guide slot. Make sure the S.E.A. logo is facing up. A “click” noise will be heard and the battery will be held in place.
- Repeat with the other holder.
- Don the respirator as per its user instructions.

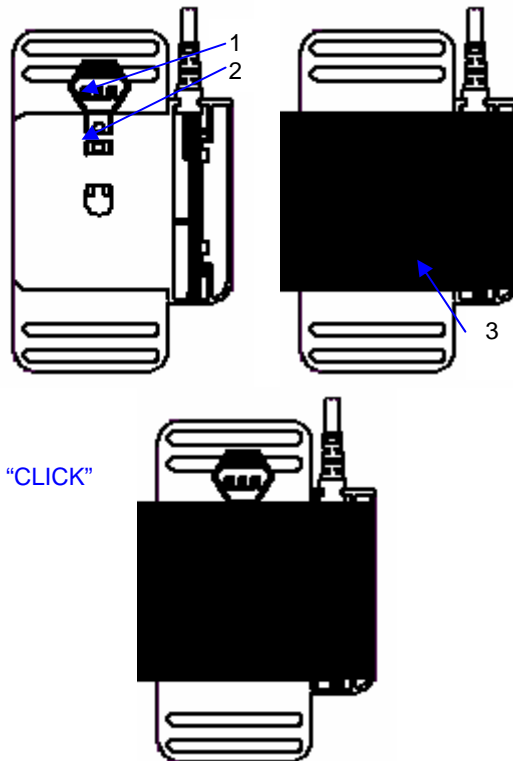

- 1) Dual Battery Key
- 2) Dual Battery Key Guide Slot
- 3) Battery, (B1 or later model)

Cleaning and maintenance:

- The Dual Battery system is water resistant. Do not subject it to direct streams of water, or submerge in water.
- To clean, wipe down with a clean, damp cloth. Do not use solvents.