

DeconFilter™ Pro S – Manual

Installation, user instructions and service



Content

2 General Description and Safety	4
2.1 To the user	4
2.2 Safety regulations	4
2.3 Limited Warranty	4
2.4 Limitation of Liability	5
3 Technical data	5
3.1 Installation drawing	6
3.1 Installation drawing – Wall Mount	6
4 Installation	7
4.1 Mounting the filter rack	7
4.2 Pressure gauge	9
4.3 Tank installation	9
4.4 Filter cartridge installation	13
5 Operation	13
6 Service & Maintenance	14
6.1 Filter change interval	14
6.2 Replacement Cartridges	15
6.3 Replacement of Filter Cartridges	15
6.4 Cleaning	15
7 Spare parts list	17

2 General Description and Safety

2.1 To the user

The **DeconFilter™** Pro S is designed with the express purpose of being used together with the Solo Rescue® Decon Washer and shall not be used in any other context. It serves the purpose of filtering the contaminated wash water from the Solo Rescue before flushing it out the drain.

This manual is your guide to the correct use of the **DeconFilter™** Pro S.

RESCUE Intellitech recommends that you study the manual thoroughly to be sure that the filter system is used correctly and safely.

Ensure that the manual is always available throughout the service life of the filter system.

RESCUE Intellitech disclaims any and all liability for any damages or injury to persons, property or otherwise resulting from misuse or failure to follow instructions found in this Manual, failure to wear hand and face protection when changing filter cartridges, and or replacing filters with cartridges that are not supplied by RESCUE Intellitech or their appointed representatives.

2.2 Safety regulations

Scalding risk. The **DeconFilter™** Pro S may contain hot, contaminated water. It may contain hazardous toxic chemicals and carcinogens.

During filter changes and while performing service and maintenance...:

- ...always wear eye protection
- ...always wear protective gloves
- ...always make sure the filter system is powered off by disconnecting the **DeconFilter™** Pro S from the electrical socket.
- ...all use of the connected Solo Rescue® Decon Washers is prohibited.

2.3 Limited Warranty

RESCUE Intellitech warrants and represents that all of its products are free of defects in materials or workmanship for a period of twelve (12) months from the date of delivery, subject to normal wear and tear and provided that the relevant **DeconFilter™** Pro S has been used in accordance with the instructions, manuals and guidelines provided by RESCUE Intellitech (as amended from time to time).

In the event that a **DeconFilter™** Pro S delivered by RESCUE Intellitech would not meet the requirements under said limited warranty (that is, there would be a defect in materials or workmanship as shown within a period of twelve months from the date of delivery), RESCUE Intellitech shall at its own cost and expense either (i) redeliver the relevant **DeconFilter™** Pro S (upon receipt of the defective product from the dealer and confirmation of the defect) or (ii) remedy the relevant defect. RESCUE Intellitech shall, at its own discretion, choose either one of remedy (i) or (ii).

Except for the limited warranty expressly stated above, neither RESCUE Intellitech nor any of its representatives or affiliates make any express or implied representation or warranty or condition with respect to any **DeconFilter™** Pro S or any other products delivered. RESCUE Intellitech disclaims any and all other representations, warranties and conditions in any form whatsoever, whether express or implied, including

without limitation, the implied warranties of merchantability, title and/or fitness for a particular purpose.

The express limited warranty above is ONLY valid if the **DeconFilter™** Pro S is installed by an authorized representative of RESCUE Intellitech. If a **DeconFilter™** Pro S would be installed, repaired or otherwise modified by someone other than an authorized representative of RESCUE Intellitech, the limited warranty shall immediately lapse.

2.4 Limitation of Liability

In no event shall RESCUE Intellitech, or any of its representatives or affiliates, whether in contract, tort or otherwise, be responsible or liable for any consequential, indirect, incidental, special, exemplary, or punitive damages arising out of or in connection with the delivery of any **DeconFilter™** Pro S products, or the use thereof, regardless of (a) whether such damages were foreseeable, or (b) whether or not RESCUE Intellitech was advised of the possibility of such damages.

Except for obligations to make payment under this agreement, each party's aggregate liability arising out of or related to this agreement, whether arising out of or related to breach of contract, tort (including negligence) or otherwise, shall not exceed the total amount paid under this agreement during the 12-month period preceding the event giving rise to the claim.

The limitations of liability set out herein shall not apply with respect to damages arising out of grossly negligent acts or omissions or wilful misconduct or misuse.

3 Technical data

Dimensions H x W x D	1800 x 300 x 750 mm (71" x 12' x 30")
Weight (empty)	70 kg (154 lbs)
Filer tank volume	130 liters (34 gallons)
Power supply	EU: 5 m (16 ft) cable with Schuko plug included. Other regions: Please contact your local dealer
Rated Voltage	220–240 VAC single phase
Fuse	10 A
Frequency	50 Hz
Rated Power	0,55 kW (0.7 hp)
Drain hose connection	19 mm (3/4"), 6m (19 ft) hose included
Minimum drain capacity min.	35 l/min (9 gallons/min)
Drain outlet height on wall max.	1,5 m (5 ft)
Filtration technology	Multi stage custom filtration including lint filter, particle filters and active carbon filter
Pump	Stainless steel, high temp, handle solids up to 10 mm (0.4").
Capacity	Up to 3 Solo Rescue Decon Washers
Options	Wall mount accessory
Filter change recommendation	Every three months, or according to pressure indicator. More often depending on application.

3.1 Installation drawing

A. Drain outlet/hose connection **B.** Pressure gauge

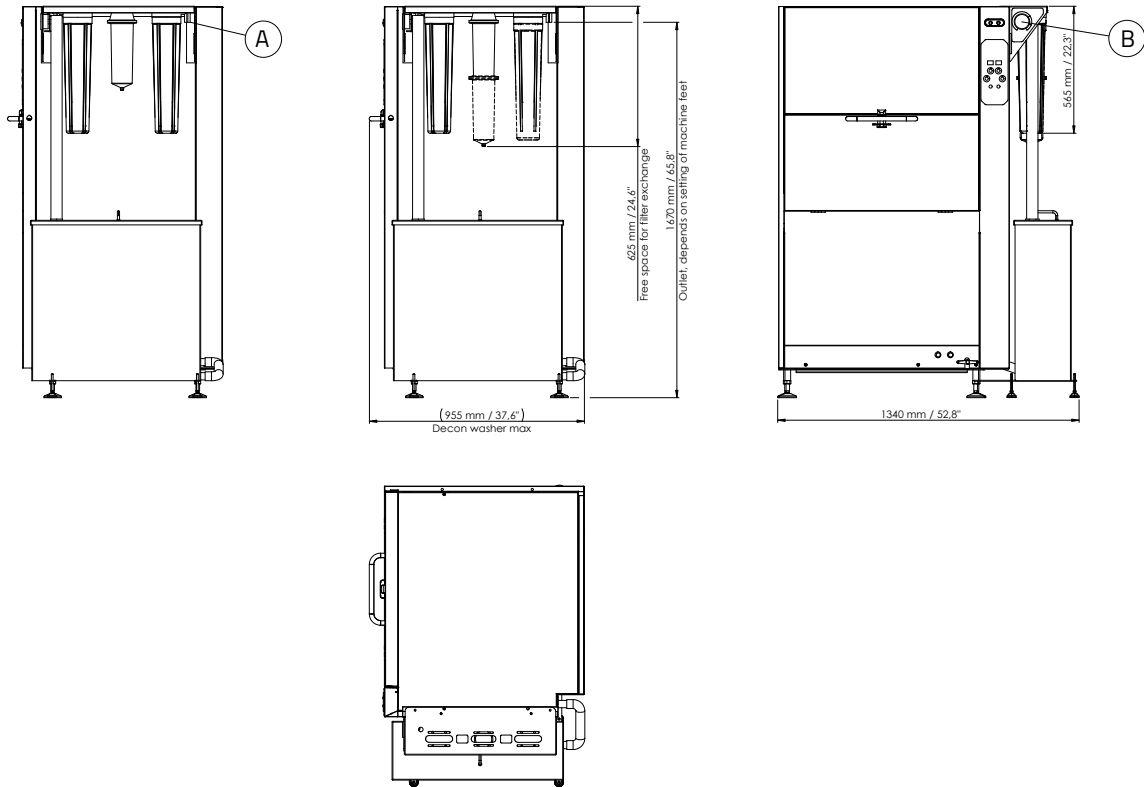

3.1 Installation drawing – Wall Mount

A. Inlet **B.** Drain outlet/hose connection **C.** Pressure gauge

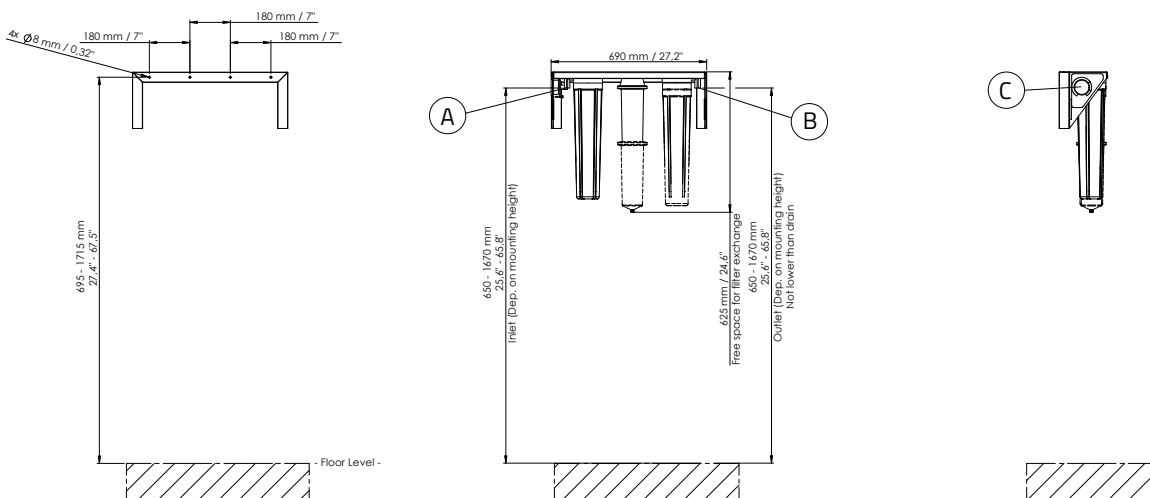

4 Installation

4.1 Mounting the filter rack

For filters mounted on the Solo Rescue – go to section 4.1.1

For wall mounted filters – go to section 4.1.2 (Option, accessory needed)

4.1.1 Mounted on the Solo Rescue®

NOTE: Not applicable for Solo Rescue® 32-series, use wall mount accessory instead. See section 4.1.2.

1. Unscrew the bolt holding the top cover on the right side of the Solo Rescue® (Fig. 1)
2. Position the filter rack pins in the holes as displayed in (Fig. 2)
3. Fasten the previously unscrewed bolt to fix the filter rack on the Solo Rescue® (Fig. 3)



Figure 1

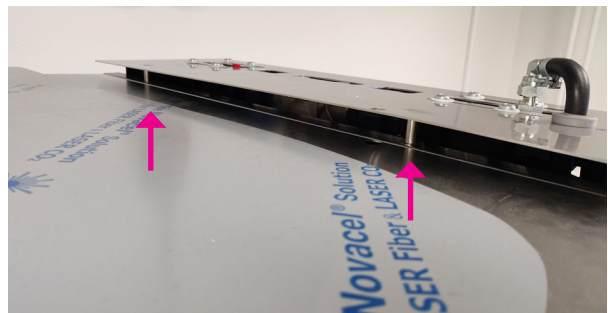

Figure 2

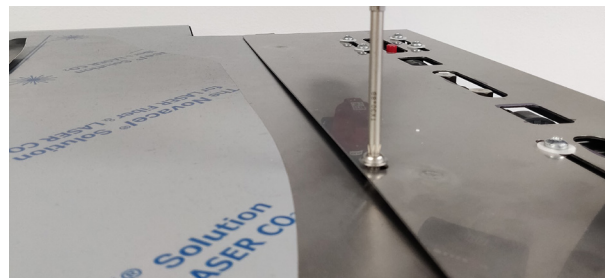

Figure 3

4 Installation

4.1.2 Mounted on the wall

Use wall mount accessory article number 27305.

IMPORTANT NOTE: Use suitable fastening (screws and plugs) based on the construction of the wall (not included in kit). Filter racks in operation weigh approximately 30 kg (66 lbs).

1. Remove the filter rack securing bolts (Fig. 4).
2. Make sure the wall mount is level. If drilling is needed, make sure to mark where as displayed in Fig. 5.
3. Fasten the wall mount on the wall using four screws in the holes as displayed in Fig. 5.
3. Position the filter rack pins in the holes (Fig. 6).
4. Fasten the previously unscrewed rack securing bolts to fix the filter rack on the wall mount (Fig. 7).

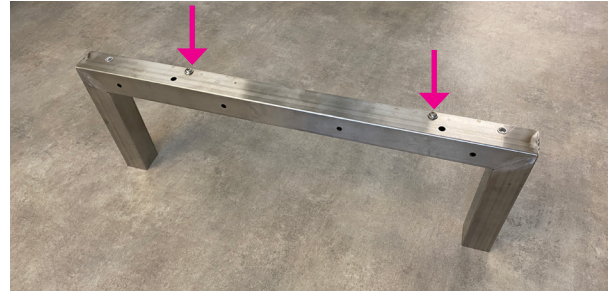

Figure 4

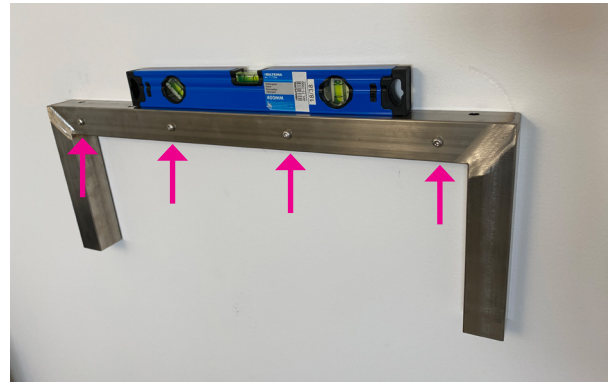

Figure 5

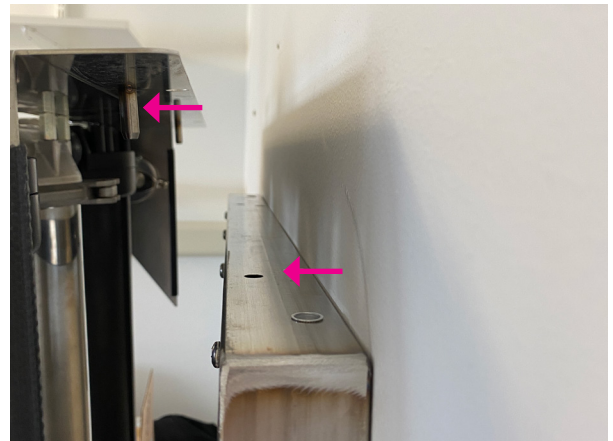

Figure 6



Figure 7

4.2 Pressure gauge

Without removing the pressure gauge from its position, gently pierce a small hole in the rubber cap on the top. (Fig. 8 & 9).



Figure 8



Figure 9

4.3 Tank installation

1. On the right hand side of the Solo Resce®, loosen the nuts on the levelling feet and position the tank. Fixate it by tightening the nuts again (Fig. 10).
2. Make sure the tank is in level by adjusting its feet (Fig. 11).

Continues on next page ->

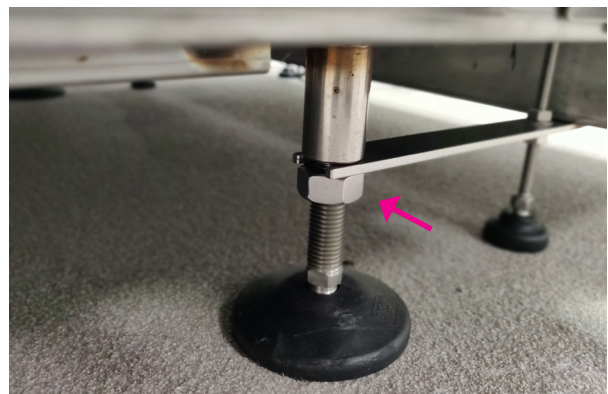

Figure 10

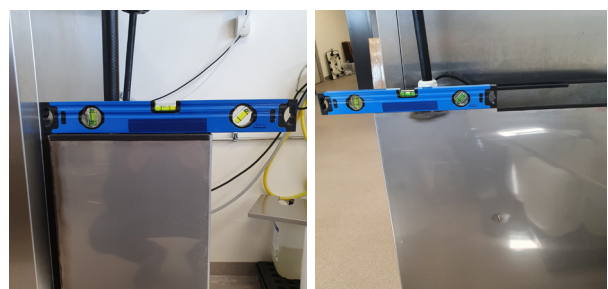

Figure 11

4 Installation

3. Once it is level, tighten the nuts on the tank feet (Fig. 12).
4. Connect the included drain pipe connections between the Solo Rescue® drain outlet and the tank inlet (Fig. 13).
5. Place the provided submersible pump in the tank and make sure the arrows on the anti-rotation plate points to the front of the tank (Fig. 14)

Continues on next page ->



Figure 12



Figure 13

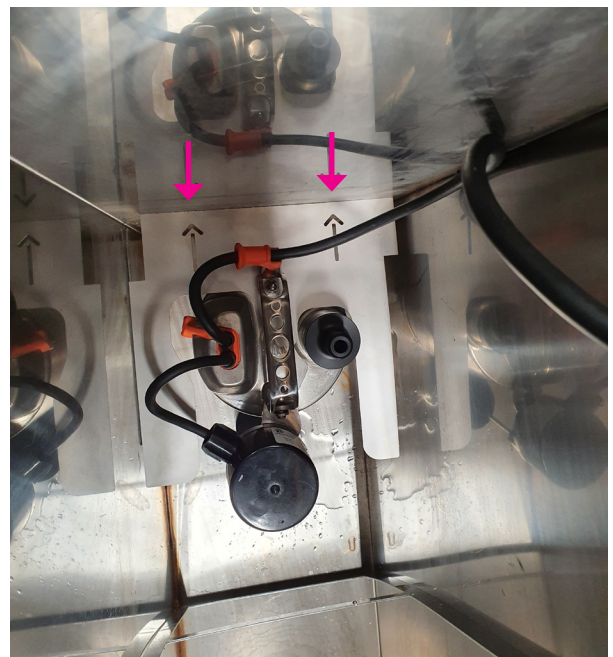

Figure 14

6. Cut the provided hose to suitable length from pump outlet to filter inlet at filter housing #1 (Fig. 15 & 16).
7. Connect the hose to the pump outlet and secure it with one of the provided hose clamps (Fig. 15).
8. Pull the hose through the cable gland and secure it to the tank using the locknut (Fig. 17).
9. Secure the power cable with the rubber grommet (Fig. 17 & 18)

Continues on next page ->

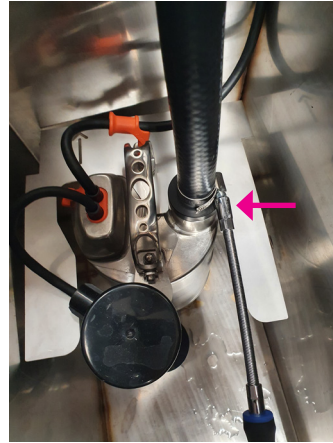

Figure 15

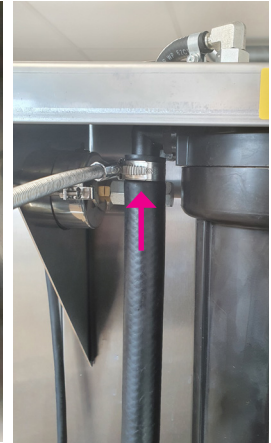

Figure 16

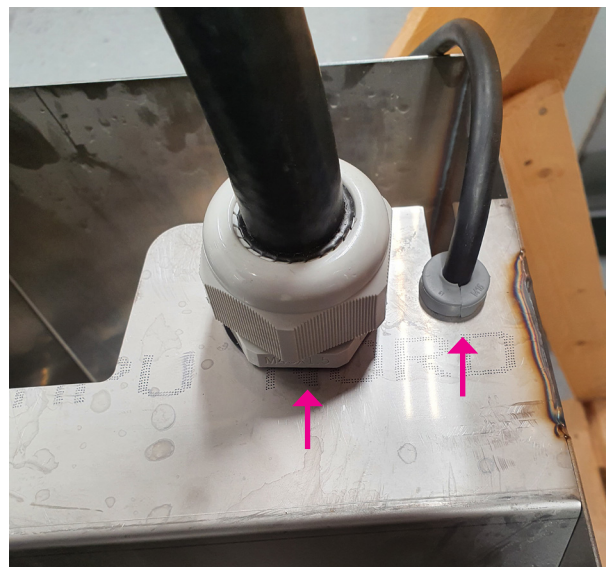

Figure 17



Figure 18

4 Installation

10. Connect the hose to the inlet of filter housing #1 secure it with one of the provided hose clamps (Fig. 19)
11. Use the remaining hose to connect the filter system to the drain on site. Cut to suitable length if needed. Connect the hose to the outlet of filter housing #3 and secure it with one of the provided hose clamps (Fig. 20).
12. Connect the other end of the hose to the drain/
floor drain according to local regulations.



IMPORTANT NOTES:

- Never use a drain hose longer than 6 m (18 ft).
 - Height of wall mounted drain outlet must never exceed 1,5 m/5 ft from the floor.
 - Avoid sharp bends or blocking's as it may limit the output flow and cause a raised pressure in the system.
13. Install lint filter with the sheet metal lip towards the pump. Slide it down until it comes to a stop (Fig. 21).



Figure 19



Figure 20

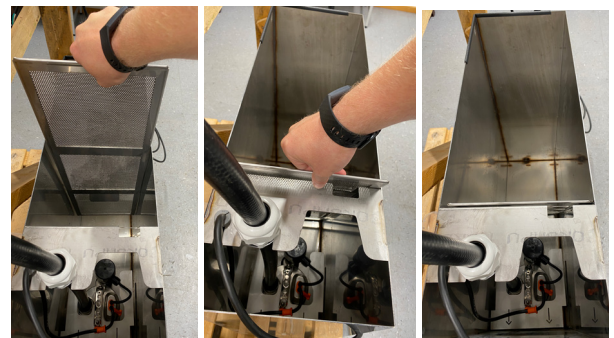

Figure 21

4.4 Filter cartridge installation

1. Unscrew the filter sumps and fit the filter cartridges in their correct positions as displayed in Fig. 22. Each filter housing and corresponding filter cartridge is marked with identical numbers to indicate its correct position.
2. Remove the transparent wrapping on each cartridge before it is mounted.
3. Filter cartridge #1 and #3 is mounted in the center of the bottom of their corresponding sumps. The sumps are then mounted to the filter housing head by gently pushing the sump upwards while rotating it clockwise.
4. When the cartridge is correctly mounted, tighten the sump with a gentle twist.
5. To fit filter cartridge #2, use some water to lubricate the O-rings on the top of the cartridge and push it by hand all the way to the top of the center socket of the #2 filter housing head. Mount the sump with the clamp and tighten it by hand.

NOTE: Filter break in – it takes a couple of water changes from the Solo Rescue before the new filter cartridges reaches their full filtering performance.



IMPORTANT NOTE: If the filter cartridges are incorrectly mounted or mounted in the wrong place, it will have a negative impact on the performance of the filter system.

5 Operation

The **DeconFilter™** Pro S is designed and built to be connected at all time and it operates without human interaction. It is advised to frequently keep an eye on the system pressure gauge while draining your Solo Rescue Decon Washers to make sure it is running correctly.

Once the filter tank gets filled up with water from



Figure 22

the connected Solo Rescue Decon Washers, a built-in float switch automatically starts the pump, transferring the water from the tank through the filter cartridges and eventually out into the drain. Once the tank is emptied the pump will automatically come to a stop.

6 Service & Maintenance



IMPORTANT NOTES: The DeconFilter™ Pro S may contain hot, contaminated water. It may contain hazardous toxic chemicals and carcinogens.

Never use other filter cartridges than the RESCUE Intellitech Replacement Cartridges together with the **DeconFilter™ Pro S**.

During filter changes and while performing service and maintenance...:

- ...always wear eye protection
- ...always wear protective gloves
- ...always make sure the filter system is powered off by disconnecting the **DeconFilter™ Pro S** from the electrical socket.
- ...it is strongly recommended to clean the tank and pump inlet.
- ...all use of the connected Solo Rescue® Decon Washers is prohibited.



6.1 Filter change interval

Every three months, or according to pressure indicator. More often depending on application.

6.1.1 Service Indicator

Monitor the System Pressure gauge (Fig. 23) on the front panel when the pump is running. It indicates when it is time for filter change and overall maintenance.

It is recommended to change filters when the pressure reaches the yellow area.

At the red area the filter cartridges **MUST** be replaced.



Figure 23

6.2 Replacement Cartridges

Replacement cartridges are provided by RESCUE Intellitech dealers only. Contact your local dealer for more information.

6.3 Replacement of Filter Cartridges

1. Disconnect the power to the submersible pump by disconnecting the **DeconFilter™ Pro S** from the electrical socket.
2. Equalize the pressure in the filters by pushing the red button on the top of filter housing #3 (Fig. 24).
3. Remove the tank lid to allow water spill to go into the tank.
4. Unscrew the filter sumps and dispose the filter cartridges according to local regulations for hazardous materials.

CAUTION: Scalding risk – hot water.

5. Clean the insides of the filter sumps and install new filter cartridges according to section 4.4 Filter cartridge installation.
6. Connect the power to the submersible pump.



Figure 24

6.4 Cleaning

6.4 Cleaning the tank.

1. Make sure the tank is empty.
2. Disconnect the power to the submersible pump by disconnecting the **DeconFilter™ Pro S** from the electrical socket.
3. Remove the lint filter and disconnect the hose from the pump outlet.
4. Remove the submersible pump from the tank (Fig. 25).
5. Remove all lint and sludge inside the tank and rinse with tap water.

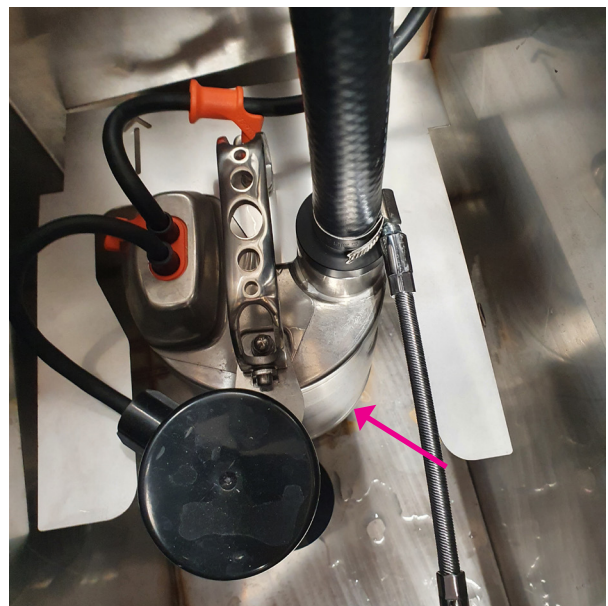

Figure 25

6.5 Cleaning pump intake (every 12 months)

1. Pull off the intake cage from the housing and remove the impeller cover by loosening all six Phillips head screws.
2. Clean and rinse the intake cage, impeller and the impeller cover with clean water (Fig. 26 & 27).

CAUTION: Do not rest the pump on the impeller.

3. Reassemble the impeller cover and push the intake cage back in place.
4. Install pump and lint filter by reversing the disassembly steps.

NOTE: There are no parts inside the pump housing which require additional maintenance.



Figure 26



Figure 27

7 Spare parts list

Item	Denomination	Part Number
1	Pump complete	90041
2	Manometer	28078
3	Filter housing #1 complete	90042
4	Filter housing #2 complete	90043
5	Filter housing #3 complete	90044
6	Pump restrictor	27454
7	Lint filter	27128
8	O-ring kit for Filter Housing 1-3	90051

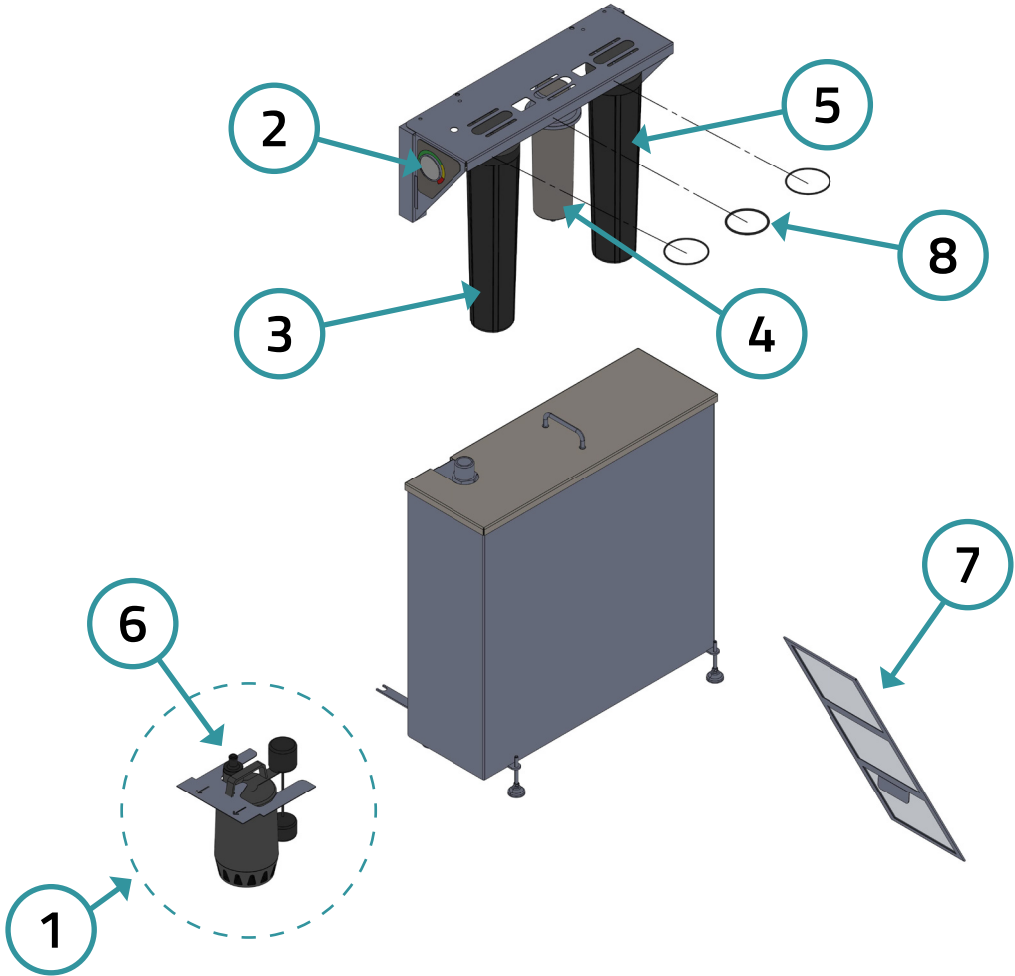



SAFETY EQUIPMENT AUSTRALIA

35/1 Jubilee Avenue
WARRIEWOOD 2102
Private Bag 1001
MONA VALE 2103

Tel: 02 9910 7500 Free
Call: 1800 655 129
Fax: 02 9979 5364

E-mail: sea.enquiries@sea.com.au
Website: www.sea.com.au

We take decontamination seriously. You should too!

Research and statistics all tell us the same story. Today's firefighters are being exposed to dangerous toxic chemicals that cause long term health problems, and even deaths. Unfortunately, fires will keep occurring and firefighters will always have to be ready when that happens. Their job is to protect us, and we have made it our mission to help protect them. Reducing the amount of toxic chemicals and carcinogens that firefighters are exposed to on a daily basis is one of several critical aspects of ensuring a safe work environment and firefighters' long-term health. With the Solo Rescue® Decon Washer, your fire department can reduce toxic chemicals and carcinogens in a quick, easy and safe way. By adding our DeconFilter™ Pro S to that process, you will also reduce the number of toxins you flush down the drain and prevent them from spreading further.